



Nature²® Purifier for Vinyl Lined Pools Operating Manual

Important Safety Information

Please read this manual prior to installation.

We believe the more you know, the more enjoyable and healthy your family’s swimming experience will be - and the more you will reduce the time, effort and cost of maintaining your pool. Pool owners who switch from chemical programs to the Nature²® purification technology spend less time maintaining their pools.

Every pool has its own characteristics of water type, amount of sunlight, etc. Discuss with your dealer the right “recipe” of water management to fit the particular circumstances of your pool and geographic climate.

Remember, your authorized Nature² dealer can provide professional advice and service.



WARNING

Failure to heed the following warnings can result in permanent injury or drowning.

EQUIPMENT UNDER PRESSURE

- Always turn pump off prior to installing or changing Nature² cartridge. Your pump/filter system is operated under pressure and the pressure must be released before you begin work. Please see your pump/filter owner’s manual for further instructions.

PREVENT CHILD DROWNING

- Do not let anyone, especially small children, sit, step, lean or climb on any equipment installed as part of your pool’s operational system. Locate the components of your operational system at least 1 m (3 ft.) from the pool so children cannot use the equipment to access the pool and be injured or drown.

Specifications

Capacity: 18,000 L - 114,000 L

Dimensions: 405 X 241 X 292 mm

Ports: 38 mm FPT threaded connections, inlet and outlet

Weight: 2.6 kg

Circulation system flow rate: 95 - 303 L/min

Purifier flow rate: 38 - 68 L/min (internal bypass)

Maximum operating pressure: 173 kPa

Cartridge dimensions: 248 x 118 mm

Replacement cartridge: A30 ec (18,000 - 114,000 L)

Important: The proper replacement cartridge for your purifier is indicated on the label located on the front of your unit.

Cartridge life: 6 months from the date of installation

Run time: 6 hours minimum

Warranty: 2 years (housing)

P.C.P. ACT REG NOs: Model NA: 24575 / Model PA: 25139

DOMESTIC

This purifier is for vinyl lined pools only.

Any other use voids manufacturer’s warranty.

Nature² Compatibility

Do not use with the following:

- Copper-based algaecides
- Bromine or bromide chemicals
- Biguanides

The Nature² Pool Purifier is designed for residential swimming pools only.

IMPORTANT: Pool Owner, save this manual. Builders, leave this manual with pool owner.

Contents

Important Safety Information	1
Specifications	1
Installation	2
Bypass Installation.....	3
Balance the Water	4
Start Up	4
Low-Chlorine Recipe	4
Provide Filtration/Circulation.....	5
Troubleshooting	5
Replacing the Nature ² Purifier Cartridge	6
Winterizing Your Pool	6
Warranty	7

Installation

If you decide to install the Nature² Purifier yourself, follow these instructions.

Under normal pump and filter pressure conditions for vinyl liner pool systems, the flow rate to the inlet side of the purifier is 95-303 L/min (80 gpm) which will allow proper flow through the cartridge.

IMPORTANT If your pump system is designed to produce flow rates greater than 303 L/min (80 gpm), ask your dealer about installing in a bypass configuration.

If the Nature² Purifier is to be installed below the water level of the pool, precautions must be taken to prevent the pool from draining during installation and during cartridge change. Valves should be installed to isolate the system for these situations.

Equipment needed:

- A set of **shut-off valves** or rubber winterizing line-plugs to use during cartridge installation or replacement to prevent draining (used in step 5).
- A filter **connector hose** of the same diameter as the other hoses on your pool equipment (used in step 7).

Install the Vessel

Refer to the diagram below for part references.

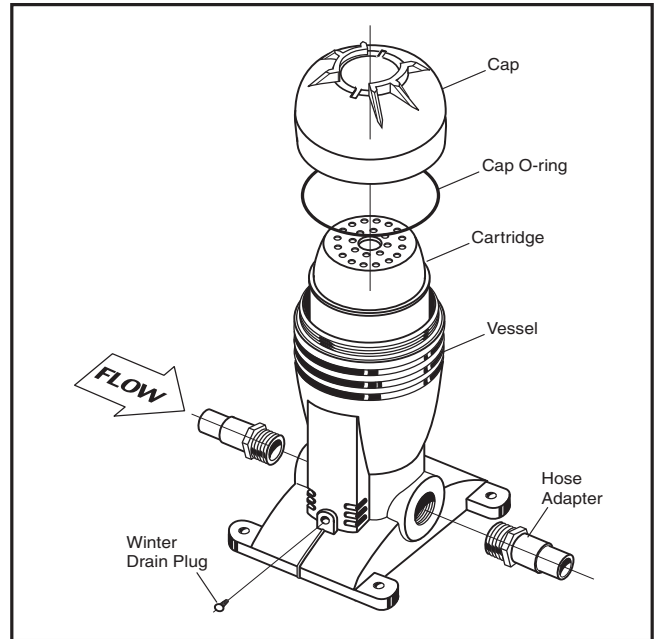

1. **Decide where** to install the Nature² vessel. It should be installed:
 - On a concrete slab to support the weight of the vessel.
 - After the filter on the main return to the pool.
 - Before or after the heater (downstream of solar heating systems).
 - Before any chemical dispenser or the discharge of any off-line chemical dispenser.

IMPORTANT

Install a check valve before chlorinators to isolate the Nature² purifier from possible backflow of highly chlorinated water .

2. **Wrap Teflon[®] tape** (supplied in the parts bag) around the threaded end of the hose adapters as follows:
 - Hold adapter with the threaded end towards you.
 - Wrap the tape clockwise until you have completed three or four wraps, overlapping about half of the tape already on the threads.

NOTE Hose adaptors provided are designed for above ground pool installations. If you are installing on an inground pool, it is recommended that you purchase the appropriate fitting for your application. Ask your dealer for more information.

3. **Hand-tighten** both hose adapters into the base of the Nature² purifier. Then, with a wrench, tighten not more than on-half turn more. The purifier is now ready to be installed.
4. **Run the pump** with a clean filter and under normal operating conditions. It is important to start with a clean filter. Fill in the pressure reading found on the pressure gauge attached to the filter.

5. **Turn off the pump and isolate the equipment** (to prevent draining the pool) by plugging all lines running from the pool to the equipment, closing in-line valves, and/or using the winterizing line plugs to seal off the skimmer pipe and all return inlets. You are now ready to insert the purifier into the pool's lines.
6. **Disconnect the hose** on the outlet side of the filter. Connect it to the outlet side of the purifier.
7. **Install a new section of connector hose** between the outlet side of the filter and the inlet side of the purifier. Use the hose clamps from the parts bag to secure the two ends of the new hose.

NOTE If your pool uses large diameter hose (1-1/2") cut off the ends of the adapter (the 1-1/4" stubs) as marked on each adapter, so they do not block the flow of water.

The new installation should be: Pool → Pump → Filter → Nature² Purifier → Pool.

8. **Remove plugs or open all valves** used to isolate the filter. Screw on the cap until it is snug. *Do not over tighten.* Check that all connections are secure.

IMPORTANT Do not install the Nature² Cartridge until the purifier installation is complete.

9. **Turn on the pool pump** and check for and repair any leaks you find.
10. Compare the pressure reading on the filter gauge with the pressure reading recorded above.

If the pressure increased by:

Between 1 and 2 psi: Pressure is good. Some increase is necessary for water to be forced into the vessel. The vessel installation is complete and ready for cartridge start-up.

More than 2 psi: There is too much pressure for the circulating pump, filter and vessel to work efficiently. The vessel may need to be connected via partial bypass. Consult your dealer.

Less than 1 psi: Use the Flow Restrictor Installation.

Flow Restrictor Installation

1. Plug any lines (or close valves) to prevent pool from losing water.
2. Disconnect hoses from vessel.
3. Remove cap and hose adapters.
4. Remove flow restrictor from the parts bag.
5. While holding the vessel with the inlet port facing up, reach in and place restrictor (fingers facing down) into the flow control collar (hole approximately 1" in diameter).

NOTE You may need to reach into the outlet port side of the unit to help position the restrictor.

6. Once the restrictor is positioned properly, place the unit on a flat, firm surface keeping the inlet port face up.
7. Apply downward pressure on restrictor using a blunt-handled tool such as the end of a broom handle until it snaps into place.
8. Reinstall the vessel and recheck the system pressure.

Bypass Installation

This 38 mm (1 1/2 in.) Nature² Purifier system may need to be installed in bypass to the filtration system if plumbing size is greater than 38 mm (1 1/2 in.) diameter or if flow rates are greater than 303 L/min (80 gpm).

The Nature² Purifier is installed on a bypass loop after the filter and always before a chemical dispenser, if equipped, as shown below.

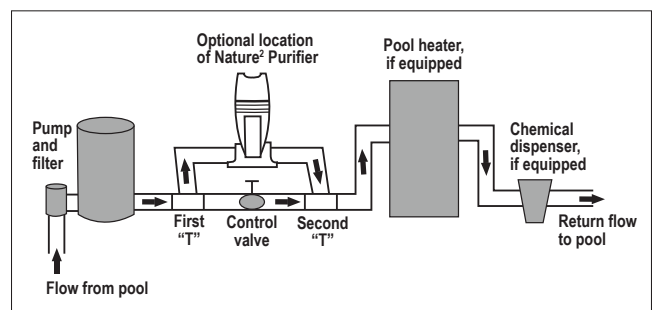

To Create the Bypass:

1. **Install a "T" in the return line** to allow water to divert to the Nature² Purifier. This "T" is then connected to the inlet of the purifier.
2. **Install a control valve in the return line** after the first "T" and before the second "T".
3. **Fully open any valves (including the control valve) that were closed** to isolate the purifier.
4. **Start the pump** allowing water to pass through the newly plumbed system. The control valve in the return line between the two "T"s will control the flow through the purifier.

NOTE For flows in excess of 303 L/min or 80 gpm with the Nature² in bypass, do not exceed a 10.3 kPa increase in filter backpressure. Once 10.3 kPa is reached in this situation the flow is corrected through the purifier.

5. **Check the purifier** for leaks and fix or replace any fittings.
6. **Follow the start up procedures.**

Balance the Water

To find out if your pool water is balanced:

- Take a water sample to your dealer to be tested regularly, or
- Ask your dealer to recommend a pool test kit for water balance.

Balance pool water before installing purifier cartridge.

- pH 7.2 - 7.8
- Total hardness 200 - 300 ppm
- Total alkalinity 80 - 120 ppm

Consult your Nature² Dealer for specific water balance instructions.

Element: pH Range: 7.2 - 7.8	If it's too low:	The surface of your pool can become etched. Metal parts in the pump and plumbing will corrode.	How to fix: Add pH increaser.
	If it's too high:	"Scale" forms on the surface of your pool. The water can become cloudy. "Scale" forms on your pool equipment.	How to fix: Add pH decreaser.
Element: Calcium Hardness Range: 200-300 ppm	If it's too low:	Water is less stable. In plaster pools, the calcium is taken out of the plaster, causing the surface to deteriorate.	How to fix: Add calcium hardness increaser.
	If it's too high:	Rough, discolored deposits ("scale") will form on the pool surface and inside pool equipment.	How to fix: Drain or dilute the pool water. Consult your dealer.
Element: Total Alkalinity Range: 80-120 ppm	If it's too low:	It provides no buffer so that you constantly get fluctuating pH readings, which can damage equipment and pool surfaces.	How to fix: Use an alkalinity increaser.
	If it's too high:	White deposits ("scale") form on the tile line. The plaster on pool surface becomes rough or discolored. The water becomes cloudy or milky white.	How to fix: Add acid to bring alkalinity down.

Start Up

Before starting up a new Nature² Cartridge, clean debris and algae out of the pool and pool equipment.

Important Do not install the new cartridge until the pool water is clean and chemically balanced.

1. **Install the cartridge** after water is balanced.
2. **Shock the pool** to burn off contaminants and to activate the cartridge. Follow label instructions of shock product being used.
3. **Run the circulation pump** either:
 - 24 hours a day for 4 days, maintaining 1-3 ppm free available chlorine, or
 - 6 hours a day for 14 days, maintaining 1-3 ppm free available chlorine.
4. **Let free available chlorine residual drop** but not below a minimum of 0.6 ppm once start-up period is completed.

Follow the Recipe

Low-Chlorine Recipe

(0.6 ppm free available chlorine minimum)

Ingredients:

- Nature² Cartridge
- Chlorine granules, tablets, liquid or generator
- pH and total alkalinity adjusting chemicals
- Calcium hardness increaser, if needed
- Water test kit
- Cyanuric acid

Once the 4-day or 14-day start-up period is done, allow the free available chlorine residual to drop but not below 0.6 ppm, then:

When:

- Every day
- Once a week
- Twice a week
- As needed

What to do:

- Run pump and filter at least 6 hours every day.
- Balance pH and total alkalinity.
- Check chlorine residual, add chlorine to maintain a minimum of 0.6 ppm free available chlorine.
 - If water is hazy, shock. Follow product label instructions.
 - After heavy use or rainstorm, shock is recommended.
 - Add cyanuric acid (stabilizer) to maintain 50 ppm.

Provide Filtration/Circulation

To manage: **You need to:**

Circulation Follow the manufacturer's directions for keeping the circulating pump in good working order and operate it at least six hours a day.

Filtration Check the pool's filter periodically and clean it as recommended by the manufacturer.

Troubleshooting Guide

Use the guide below to correct common pool issues. For further assistance, consult your Nature² dealer or call us at 1-800-822-7933.

	Problem	What to look for	Treatment
Cloudy Water Frequently caused by improper start up. See section on Start Up.	Poor filtration	Slow filter turnover rates.	1. Backwash and clean filter. 2. Run filter for 24 hours. 3. Increase run time per day.
	Algae growth	Hazy pool water; may have slightly green appearance.	Shock water (with dealer's guidance) and brush pool walls.
	Unbalanced water	1. High Hardness. 2. High TDS (total dissolved solids). 3. High pH. 4. High total alkalinity.	Balance the pool water.
Algae	Green algae	Pea green colour; attaches to pool walls; sometimes colours the entire body of water.	1. Check pH and adjust if necessary 2. Shock water and brush pool walls. 3. Repeat steps 1 and 2 until algae is gone.
	Black algae	Black spots on pool walls.	1. Brush affected areas. 2. Shock water.
	Mustard algae	Yellow or brown film on steps or walls.	3. Add algacide. 4. Vacuum pool. 5. Repeat steps 1 through 4 until algae is gone.
Note: Regular algacide treatments are recommended for outdoor pools that experience persistent algae problems. Do not use algae treatments containing either copper or sodium bromide.			
Stains	Blue/green	Copper or iron from pool equipment corrosion or water supply.	1. Adjust pH and total alkalinity to ideal ranges. 2. Vigorously brush stained areas.
	Red/brown	Iron or manganese from equipment corrosion or water supply.	3. Add sequestrant. 4. Run filter.
	Black	Manganese in water supply.	5. Twelve hours later, shock the pool. 6. Test and balance water. 7. Test pool water for dissolved metals.
	Metal tarnishing	High native material content in water; unbalanced water.	Clean with soft cloth and mild detergent. Test water for minerals; use a sequestrant; maintain water balance.
Scale	Crusty deposits on pool surfaces	High pH and high total alkalinity.	Adjust pH and total alkalinity to ideal ranges.
		High TDS (total dissolved solids) or high hardness levels.	1. Replace a volume of pool water with water low in calcium and dissolved solids. 2. Use sequestrant to prevent scale buildup if high hardness levels are a continuing problem.
Equipment	The purifier leaks	A. O-ring missing or improperly seated; or	Lubricate O-ring with Teflon or silicone lubricant. Note: Do not use petroleum-based lubricants (will void warranty). Be sure O-ring is seated properly before securing housing cap.
		B. Faulty plumbing.	Repair source of leak in plumbing.
	No flow to purifier	Dirty filter (one indication: pressure 55-69 kPa higher than normal).	Clean or backwash filter so operating pressure is always within 48 kPa of a new filter.

Replacing the Nature² Purifier Cartridge

The cartridge lasts six (6) months from the date of installation under normal operating conditions.

To replace the cartridge:

1. **Shut off your pool's pump and filter.**
2. **Close any valves between the filter and pool** to prevent draining the pool.
3. **Unscrew the housing cap** by twisting the cap counter-clockwise until the cap is free of the housing base. If the cap is hard to twist, use a long-shafted screwdriver as a twist handle, placing it in the slot at the top of the housing cap.
4. **Lift out the old cartridge** and replace the O-ring with the new one provided in the cartridge box.
5. **Insert the new cartridge.**
6. **Set the O-ring and cap in place** and screw the cap clockwise until it is snug. Do not overtighten.
7. **Open any valves that were closed** to isolate the Nature² Purifier in step 2.
8. **Restart your pool's pump.** Check for leaks and fix any leaking fittings.
9. **Follow the start up procedures** described on page 4.

Winterizing Your Pool

Use these steps as a guide. Consult your dealer for specific information in your area.

Warm Climate

1. **Reduce the number of hours the pump runs** since the cooler weather decreases the spread of algae and other pollutants.
2. **There is no need to shock** the pool during cool weather unless the water becomes cloudy (as may occur after a winter storm). See Cloudy Water in Troubleshooting section.

Cold Climate

1. **Check total alkalinity and pH** of pool to make sure that they are in proper balance.
2. **Vacuum the pool bottom** to remove any debris or other potential contaminants.
3. **Shock** the pool to clear the water.
4. **Add a winter algaecide** following manufacturer's instructions.

IMPORTANT

Do not use a winter algaecide with copper in it. This will void the Nature² no-stain warranty.

5. **Backwash the filter.**
6. **Drain part of the pool water.** The amount to drain varies from one part of the country to another. Consult your dealer for advice.
7. **Winterize the purifier** as follows:
 - Unscrew the housing cap from the purifier base.
 - Remove the winter drain plug and drain the water completely out of the base of the purifier.
 - Lift out the purifier cartridge and dispose of it.
 - Set the housing cap and cap O-ring in place and screw it tight.
 - Store the purifier with your pool equipment, indoors if possible.
8. **Winterize the pipes** with pool antifreeze following manufacturer's instructions.
9. **Drain the water out of all equipment** (pump, filter, etc.).
10. **Store** all baskets, hoses and cleaning equipment, indoors if possible.
11. **Cover the pool** with a winter cover.

Warranty

HOUSING WARRANTY

The Nature²® Purifier you have purchased was manufactured with care and is warranted to be free of defects in materials and workmanship for two (2) years from the date it was installed. Your warranty registration card must be completed and mailed to Zodiac Pool Systems, Inc. to establish your installation date. This warranty does not cover damage caused by abuse, misuse, accidents, or any alterations to the purifier. Report claims to your Nature² dealer. Zodiac Pool Systems, Inc. reserves the right to replace any purifier instead of repairing it.

SIX-MONTH PRO-RATED CARTRIDGE WARRANTY

The Nature² Purifier cartridges are warranted to be free of defects in materials and workmanship and to perform to your satisfaction for a period of six (6) months from the date of installation. This warranty does not cover damage caused by accident, misuse, or alteration or by the use of any biguanide, copper-based algaecides or any products containing bromine or bromide-based chemicals. If the cartridge is defective or does not perform to your complete satisfaction for the entire six (6) months, we will make prorated rebate based on your actual period of use. Please consult this Owner's Manual for proper use.

NON-STAINING WARRANTY

Your Nature² Purifier cartridge is warranted not to cause copper staining in your pool. This warranty requires only that you exercise reasonable care of your pool and keep water in balance at all times, and not use a copper-based algaecide. This Nature² Owner's Manual will guide you as to how to maintain your pool properly when using the Nature² Purifier. This warranty does not cover discoloration to chromium fittings which may discolor slightly over time and are easily cleaned with mild detergent.

There are no other warranties, expressed or implied. All incidental and consequential damages are excluded from the warranty except where provincial law is different. This warranty gives you specific legal rights. You may have other rights which vary from province to province. Proof of purchase is required to make any claims on the above warranties, so please keep your dated receipt.

* All trademarks used herein are the properties of their respective owners.

Zodiac Pool Systems, Inc.
2620 Commerce Way, Vista, CA 92081
1.800.822.7933 | www.ZodiacPoolSystems.com

For warranty support in Canada:
Zodiac Pool Systems Canada, Inc.
2115 South Service Road West, Unit 3
Oakville, Ontario • Canada L6L 5W2
Tel: 888-647-4004 • Fax: 905-825-5780

*ZODIAC® is a registered trademark of Zodiac International, S.A.S.U., used under license.
All trademarks referenced herein are the property of their respective owners.*

©2013 Zodiac Pool Systems, Inc. W17557 Rev B

